

Life Cycle Assessment

CENTRIA 3" Formawall® Dimension Series®
and Two Comparable Multi-Component Wall Assemblies

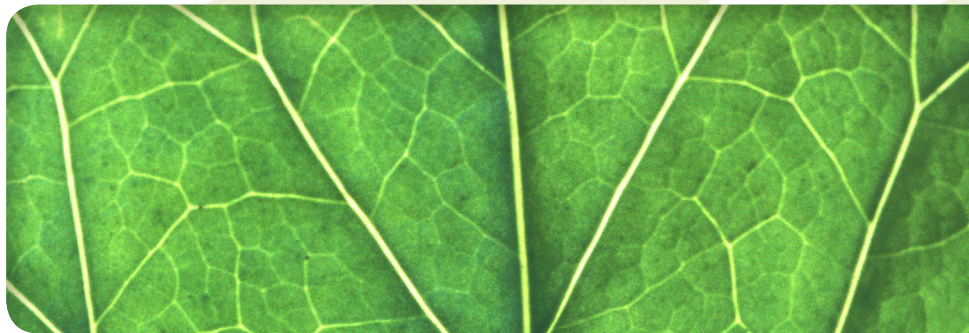

by

Five Winds International
in collaboration with PE Americas



CENTRIA

REIMAGINING THE BUILDING ENVELOPE

Life Cycle Assessment of CENTRIA 3" Formawall® Dimension Series®

and Two Comparable Multi-Component Wall Assemblies

CENTRIA, an industry leader in building envelope assemblies and the manufacturer of the first Cradle-to-Cradle^{CM} certified exterior building product, takes an active role in making a difference in the building and construction industry. As a sustainability leader, we set the pace through our products and practices and challenge others to reimagine building products and how they fit into our world.

OUR ENVIRONMENTAL VISION

CENTRIA will meet the sustainability needs of customers by developing environmentally friendly products, reduce our consumption of water, energy and harmful chemicals and continue on our path of social responsibility.

RAISING THE SUSTAINABILITY BAR

Working toward our goal to continually improve the environmental performance of our products, CENTRIA engaged Five Winds International in collaboration with PE Americas to conduct a Life Cycle Assessment (LCA) study of our 3" Formawall Dimension Series (FWDS) product. The focus of the study was to:

- 1) Examine the effects of selected life cycle stages and environmental impacts of CENTRIA 3" FWDS and;
- 2) Compare these effects with two alternative multi-component wall assemblies:
 - Precast concrete
 - Aluminum composite material (ACM)

Wall Assembly Comparison

Formawall Dimension Series

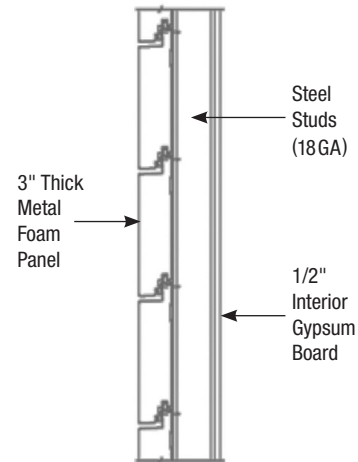

Precast Concrete

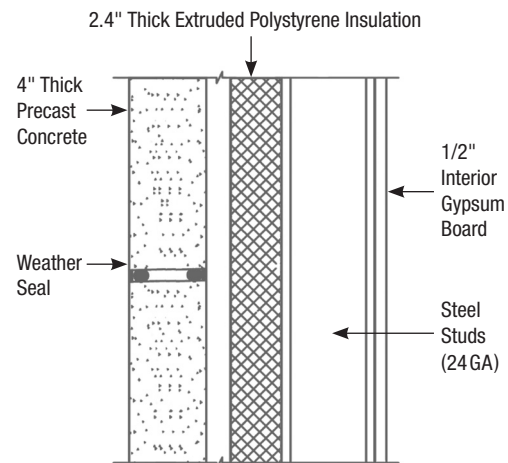

ACM Wall Panel

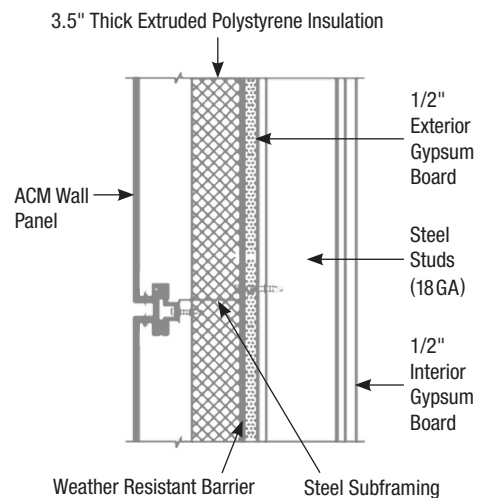

PRODUCT OVERVIEW

Formawall Dimension Series is an insulated composite wall panel consisting of a painted steel face and liner elements, a factory foamed-in-place core and pressure equalized panel joinery with no exposed clips, fasteners or sealants. The insulating core and integrated air and vapor barrier provide thermal insulation and moisture control.

Formawall Dimension Series Cradle-to-Gate

The cradle to manufacturing gate production of 3" FWDS dominates all environmental impact indicators. In addition, for most of the environmental indicators, the cradle to manufacturing gate production of CENTRIA's galvanized steel coil dominates the cradle to manufacturing gate production of 3" Formawall Dimension Series. The initial production of steel coil accounts for the following percentages of the 3" Formawall Dimension Series' cradle to manufacturing gate impacts:

68% of Global Warming Potential
48% of Primary Energy Demand
57% of Acidification Potential
36% of Eutrophication Potential
57% of Smog Potential
23% of Ozone Depletion Potential
100% of Ecotoxicity Potential
4% of Human Toxicity Potential

Steel coil production impact on Formawall Dimension Series

* For a description of some of these topics, see the Glossary of Terms section of this report.

THE STUDY: LIFE CYCLE STAGES

The life cycle stages included in this LCA study address:

- Raw material extraction
- Production and transportation of all materials
- Product manufacturing
- Packaging
- Installation
- Maintenance
- End-of-life treatment

LCA Study Functional Unit Overview

The LCA excludes the building use phase impacts such as heating or cooling. However, all wall assemblies were designed to conform to the minimum prescriptive requirements in accordance with climate Zone 5 of

Proposed Addendum bb to ASHRAE Standard 90.1-2007 for a low- or mid-rise commercial building. For the competitive study, a 3"-thick Formawall Dimension Series panel was compared with precast concrete and ACM. All were built as wall assemblies with a surface area of 360 square feet.

The report evaluates the cradle through construction stage, maintenance and end-of-life impacts of three wall assemblies and has undergone external, independent critical review and fully complies with the ISO 14040/14044 standards.

KEY FINDINGS

The study results show that the 3" FWDS wall assembly has a comparable or lower total environmental impact potential than either the ACM or the precast concrete wall assembly for most environmental indicators evaluated in this study. For example, see the global warming chart below.

FWDS Cradle to Gate Global Warming Potential per 100 sq ft

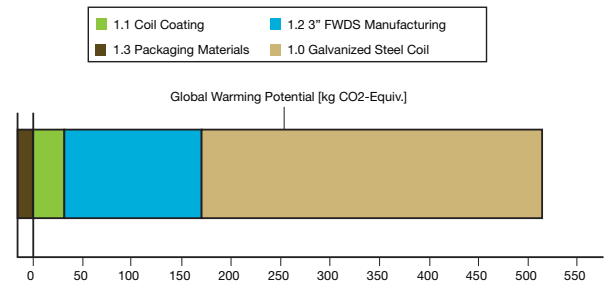

Category	Global Warming Potential [kg CO2-Equiv.]
1. CENTRIA 3" FWDS Manufacturing	498.0
1.1 Coil Coating	31.5
1.2 3" FWDS Manufacturing	139.0
1.3 Packaging Materials	-15.9
1.0 Galvanized Steel Coil	344.0

Global Warming Potential per 100 sq ft

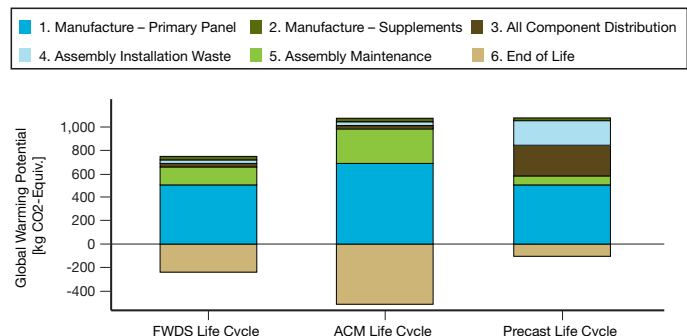

3" Formawall Dimension Series vs. Precast Concrete

According to the Life Cycle Assessment, 3"-thick Formawall Dimension Series has a better overall environmental profile than precast concrete. Both the 3" Formawall Dimension Series and precast wall assemblies were designed as minimally code compliant by Proposed Addendum bb to ASHRAE 90.1-2007. The standard requires less insulation for mass walls like precast assemblies. This study also conducted a sensitivity analysis based on different thicknesses of insulation for the precast assembly. Based on this sensitivity analysis, small changes in the insulation thickness do not change the study results.

In cradle through wall construction, the precast concrete panel has significantly larger potential environmental impact than the Formawall Dimension Series assembly for global warming, acidification and smog potential. There is not a significant difference in eutrophication potential or non-renewable primary energy demand, and the precast concrete panel is environmentally preferred to the Formawall Dimension Series in terms of ozone depletion potential.

3" Formawall Dimension Series vs. ACM

In cradle through wall construction, the ACM panel has a significantly larger potential environmental impact than Formawall Dimension Series for global warming potential, non-renewable primary energy demand, acidification potential and smog potential. There is not a significant difference in eutrophication or ozone depletion potential.

Environmental Factors

In an effort to bring consistency to the metrics of environmental impact in Life Cycle Assessment, the EPA developed TRACI (Tools for the Reduction and Assessment of Chemical and Other Environmental Impacts). TRACI normalization is an optional step within the LCA process to help further interpret the significance of multiple environmental factors.

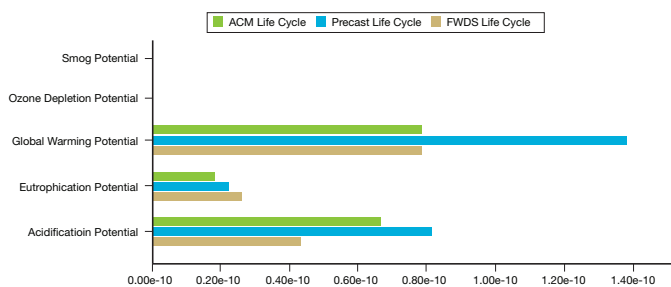

Based on TRACI normalization factors, all three wall assemblies contribute significantly more to global warming potential, eutrophication potential and acidification potential than to smog and ozone depletion potential. The impacts for smog and ozone depletion potential are insignificantly low.

Summary

The Life Cycle Assessment helps validate the superior sustainable attributes of Formawall Dimension Series. The LCA also encourages CENTRIA to continue to minimize its FWDS environmental impacts. For example:

- The LCA process helped CENTRIA identify a chemical cleaner that was used during the manufacturing process and replace it with a more environmentally friendly cleaner.
- CENTRIA has formalized a Reuse, Recycle and Take-Back program for foam panels to help ensure longer product life and avoid landfill disposal.

Glossary of Terms

- **ACIDIFICATION POTENTIAL** — Acidification refers literally to processes that increase the acidity (hydrogen ion concentration) of water and soil systems.
- **EUTROPHICATION POTENTIAL** — The most common impairment of surface waters in the U.S. is eutrophication caused by excessive inputs of phosphorus (P) and nitrogen (N). Impaired waters are defined as those that are not suitable for designated uses such as drinking, irrigation, by industry, recreation or fishing.
- **GLOBAL WARMING POTENTIAL** — Global climate change refers to the potential change in the Earth's climate caused by the build-up of chemicals (i.e. "greenhouse gases") that trap heat from the reflected sunlight that would have otherwise passed out of the Earth's atmosphere. Since pre-industrial times, atmospheric concentrations of CO₂, CH₄ and N₂O have climbed by more than 30%, 145% and 15%, respectively.
- **PHOTOCHEMICAL SMOG CREATION POTENTIAL** — Ozone (O₃) is a reactive oxidant gas produced naturally in trace amounts in the Earth's atmosphere. Rates of ozone formation in the troposphere are governed by complex chemical reactions, which are influenced by ambient concentrations of oxides of nitrogen (NOx), volatile organic compounds (VOCs), the mix of OCs, temperature, sunlight and convective flows. Ozone in the troposphere leads to detrimental impacts on human health and ecosystems. The mid-point associated with photochemical oxidant formation is the formation of ozone molecules (O₃) in the troposphere.



CENTRIA
REIMAGINING THE BUILDING ENVELOPE

For more information visit
www.CENTRIA.com/reimaginemetal
and go to our Education Center.